

T40B

Torque Flange

Special features

- Nominal (rated) torques 50 N·m, 100 N·m, 200 N·m, 500 N·m, 1 kN·m, 2 kN·m, 3 kN·m, 5 kN·m and 10 kN·m
- Nominal rated rotational speed up to 24000 rpm (depending on nominal range and option)
- Accuracy class 0.05 (50 N·m: 0.1)
- Large measurement frequency range up to 6 kHz (-3 dB)
- Digital transmission of measured values
- Compact design
- Low rotor weights and mass moments of inertia
- Optional: rotational speed measuring system, reference signal



Overall concept

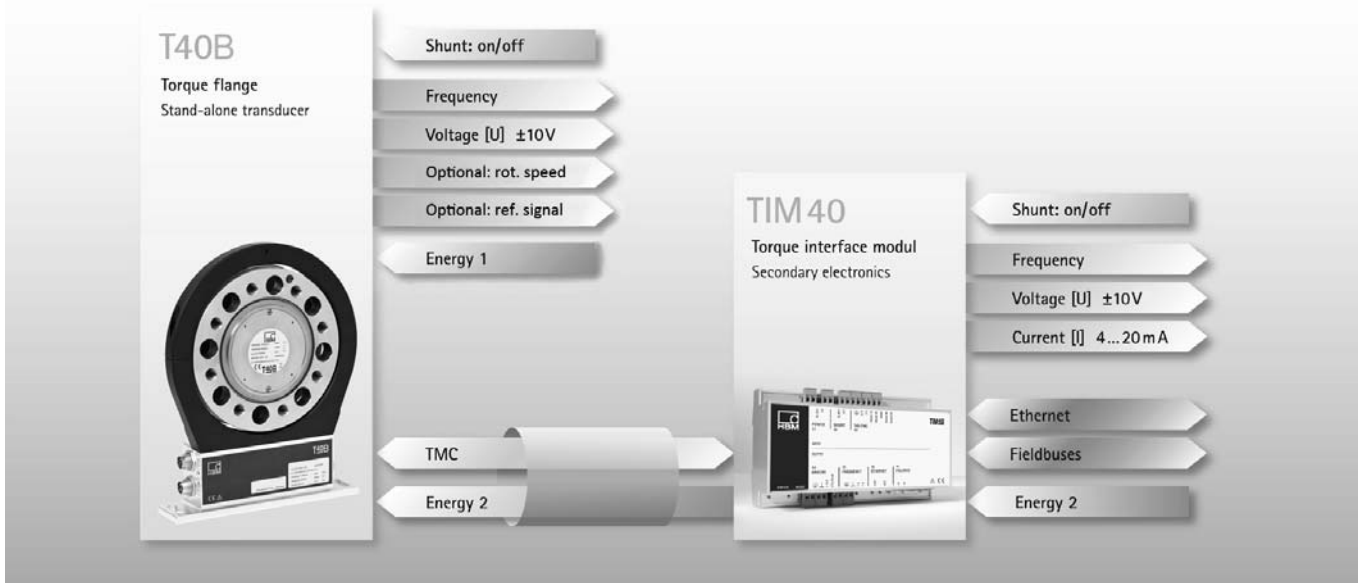

Specifications

Type	T40B										
Accuracy class	0.1		0.05								
Torque measuring system											
Nominal (rated) torque M_{nom}	N-m	50	100	200	500						
	kN-m					1	2	3	5	10	
Nominal (rated) rotational speed standard speed (option M) high speed (option H)	U/min	20000				15000	12000	10000			
	U/min	24000		23000		18000	14000	12000			
Non-linearity including hysteresis, related to the nominal (rated) sensitivity Frequency output For a max. torque in the range: between 0% of M_{nom} and 20% of M_{nom} > 20% of M_{nom} and 60% of M_{nom} > 60% of M_{nom} and 100% of M_{nom} Voltage output For a max. torque in the range: between 0% of M_{nom} and 20% of M_{nom} > 20% of M_{nom} and 60% of M_{nom} > 60% of M_{nom} and 100% of M_{nom} Relative standard deviation of the repeatability, per DIN 1319, related to the variation of the output signal Frequency output Voltage output	%					< ± 0.01					
	%					< ± 0.02					
	%					< ± 0.03					
	%					< ± 0.01					
	%					< ± 0.02					
	%					< ± 0.03					
Temperature effect per 10 K in the nominal (rated) temperature range on the output signal, related to the actual value of the signal span Frequency output Voltage output on the zero signal, related to the nominal (rated) sensitivity Frequency output Voltage output	%	± 0.1					± 0.05				
	%	± 0.4					± 0.2				
	%	± 0.1					± 0.05				
	%	± 0.2					± 0.1				
	Nominal (rated) sensitivity (span between torque = zero and nominal (rated) torque) Frequency output 10 kHz / 60 kHz / 240 kHz Voltage output Sensitivity tolerance (deviation of the actual output quantity at M_{nom} from the nominal (rated) sensitivity) Frequency output Voltage output	kHz					5/30/120				
		V					10				
%						± 0.1					
%						± 0.1					
Output signal at torque = zero Frequency output Voltage output	kHz					10/60/240					
	V					0					
Nominal (rated) output signal Frequency output with positive nominal (rated) torque with negative nominal (rated) torque Voltage output with positive nominal (rated) torque with negative nominal (rated) torque	kHz					15 ¹⁾ / 90 ²⁾ / 360 ³⁾ (5 V symmetrical ⁴⁾)					
	kHz					5 ¹⁾ / 30 ²⁾ / 120 ³⁾ (5 V symmetrical ⁴⁾)					
	V					+10					
	V					-10					
	Load resistance Frequency output Voltage output Long-term drift over 48 h at reference temperature Frequency output Voltage output	kΩ					≥ 2				
kΩ						≥ 10					
%		< ± 0.06					< ± 0.03				
Measurement frequency range, -3 dB Group delay	kHz					1 ¹⁾ / 3 ²⁾ / 6 ³⁾					
	μs					< 400 ¹⁾ / < 220 ²⁾ / < 150 ³⁾					
Residual ripple Voltage output ⁵⁾	mV					< 40					

1) Option 5, 10 ± 5 kHz (code SU2)

2) Option 5, 60 ± 30 kHz (code DU2)

3) Option 5, 240 ± 120 kHz (code HU2)

4) RS-422 complementary signals, note termination resistance.

5) Signal frequency range 0.1 to 10 kHz

Specifications (continued)

Nominal (rated) torque M_{nom}	N·m	50	100	200	500						
	kN·m					1	2	3	5	10	
Maximum modulation range ⁶⁾ Frequency output Voltage output	kHz V	2.5 to 17.5 ¹⁾ / 15 to 105 ²⁾ / 60 to 420 ³⁾ -12 to +12									
Energy supply Nominal (rated) supply voltage (separated extra-low DC voltage) Current consumption in measuring mode Current consumption in startup mode Nominal (rated) power consumption Maximum cable length	V A A W m	18 to 30 < 1 < 4 (typ. 2) 50 μ s < 10 50									
Shunt signal Tolerance of the shunt signal, related to M_{nom} Nominal (rated) trigger voltage Trigger voltage limit Shunt signal ON Shunt signal OFF	% V V V V	approx. 50% of M_{nom} < \pm 0.05 5 36 min. >2.5 max. <0.7									
Rotational speed measuring system											
Measurement system		Magnetic, via AMR sensor (Anisotropic Resistive Effect) and magnetized plastic ring with embedded steel ring									
Magnetic poles		72	86	108	126	156					
Maximum positional variation of the poles		50 angular seconds									
Output signal	V	5 V symmetrical (RS-422); 2 square wave signals approx. 90° phase shifted									
Pulses per revolution		1024 (Option 6, Code 1 & A) 128 (Option 6, Code 2 & B)									
Min. rotational speed for sufficient pulse stability	rpm	0									
Pulse tolerance ⁷⁾	degrees	< \pm 0.05									
Maximum permissible output frequency	kHz	420									
Group delay	μ s	<150									
Radial nominal (rated) distance between sensor head and magnetic ring (mechanical distance)	mm	1.6									
Working distance range between sensor head and magnetic ring	mm	0.4 to 2.5									
Max. permissible axial displacement of the rotor to the stator ⁸⁾	mm	\pm 1.5									
Hysteresis of direction of rotation reversal in the case of relative vibrations betw. rotor and stator Torsional vibration of the rotor Horizontal stator vibration displacement	degrees mm	<approx. 0.2 <approx. 0.5									
Magnetic load limit Remanent flux density Coercive field strength	mT kA/m	>100 >100									
Permissible magnetic field strength for signal deviations	kA/m	<0.1									
Load resistance ⁹⁾	k Ω	\geq 2									
Reference signal measuring system (0 index)											
Measurement system		Magnetic, with Hall sensor and magnet									
Output signal	V	5 V symmetrical (RS-422)									
Pulses per revolution		1									
Min. rotational speed for sufficient pulse stability	rpm	2									
Pulse width, approx.	degrees	0.088									
Pulse tolerance ⁷⁾	degrees	< \pm 0.05									
Group delay	μ s	<150									
Axial nominal (rated) distance between sensor head and magnetic ring (mechanical distance)	mm	2.0									
Max. permissible axial displacement of rotor to stator ⁸⁾	mm	\pm 1.5									

⁶⁾ Output signal range in which there is a repeatable correlation between torque and output signal.

⁷⁾ At nominal (rated) conditions.

⁸⁾ The data refers only to a central axial alignment. Deviations lead to a change in pulse tolerance.

⁹⁾ Note the termination resistances as per RS-422.

Specifications (continued)

Nominal (rated) torque M_{nom}	N·m	50	100	200	500							
	kN·m					1	2	3	5	10		
General information												
EMC												
Emission (per FCC 47, Part 15, subpart C) ¹⁰⁾	–											
Emission (per EN 61326–1, Section 7) RFI field strength) ¹¹⁾	–	Class B										
Immunity from interference (EN 61326–1, Table 2)												
Electromagnetic field (AM)	V/m	10										
Magnetic field	A/m	100										
Electrostatic discharge (ESD)												
Contact discharge	kV	4										
Air discharge	kV	8										
Fast transients (burst)	kV	1										
Impulse voltages (surge)	kV	1										
Conducted interference (AM)	V	10										
Degree of protection per EN 60529		IP 54										
Reference temperature	°C	23										
Nominal (rated) temperature range	°C	+10 to +70										
Operating temperature range ¹²⁾	°C	–20 to +85										
Storage temperature range	°C	–40 to +85										
Mechanical shock per EN 60068–2–27 ¹³⁾												
Number	n	1000										
Duration	ms	3										
Acceleration (half sine)	m/s ²	650										
Vibrational stress in 3 directions per EN 60068–2–6 ¹³⁾												
Frequency range	Hz	10 to 2000										
Duration	h	2.5										
Acceleration (amplitude)	m/s ²	200										
Load limits ¹⁴⁾												
Limit torque, related to M_{nom} ¹⁵⁾	%	400	200					160				
Breaking torque, related to M_{nom} ¹⁵⁾	%	800	> 400					> 320				
Longitudinal limit force ¹⁶⁾	kN	5	5	10	13	19	30	35	60	80		
Lateral limit force ¹⁶⁾	kN	1	1	2	4	5	9	10	12	18		
Limit bending moment ¹⁶⁾	N·m	50	50	100	200	220	560	600	800	1200		
Oscillation width per DIN 50100 (peak-to-peak) ¹⁷⁾	N·m	200	200	400	1000	2000	4000	4800	8000	16000		

¹⁰⁾ Option 7, Code U

¹¹⁾ Option 7, Code S

¹²⁾ Heat conductance via the stator base plate necessary over 70°C. The temperature of the base plate must not exceed 85°C.

¹³⁾ The antenna ring and connector plug must be fixed.

¹⁴⁾ Each type of irregular stress (bending moment, lateral or longitudinal force, exceeding nominal (rated) torque), can only be permitted up to its specified load limit, provided none of the others can occur at the same time. If this condition is not met, the limit values must be reduced. If 30% of the limit bending moment and lateral limit force occur at the same time, only 40% of the longitudinal limit force is permissible and the nominal (rated) torque must not be exceeded. The effects of permissible bending moments, longitudinal and lateral forces on the measurement result are $\leq \pm 0.3\%$ (50 Nm: $\leq \pm 0.6\%$) of the nominal (rated) torque. The load limits only apply for the nominal (rated) temperature range. At temperatures $< 10^\circ\text{C}$, load limits are expected to reduce by up to 30%, because the strength reduction increases as the temperatures fall.

¹⁵⁾ With a static loading.

¹⁶⁾ Static and dynamic.

¹⁷⁾ The nominal (rated) torque must not be exceeded.

Specifications (continued)

Nominal (rated) torque M_{nom}	N·m	50	100	200	500					
	kN·m					1	2	3	5	10
Mechanical values										
Torsional stiffness c_T	kN·m/rad	180	180	360	745	1165	2515	3210	5565	14335
Torsion angle at M_{nom}	degrees	0.016	0.032	0.032	0.038	0.049	0.046	0.054	0.051	0.040
Stiffness in the axial direction c_a	kN/mm	285	285	540	450	580	540	570	760	960
Stiffness in the radial direction c_r	kN/mm	160	160	315	560	860	1365	1680	2080	2940
Stiffness during the bending moment round a radial axis c_b	kN·m/deg.	1.9	1.9	3.6	4.2	5.9	9	9.3	20.2	45.5
Maximum deflection at longitudinal limit force	mm	< 0.04			< 0.05		< 0.06		< 0.08	< 0.09
Additional max. radial deviation at lateral limit force	mm	< 0.02								
Additional plumb/parallel deviation at limit bending moment (at $\varnothing d_B$)	mm	< 0.06			< 0.11	< 0.09	< 0.18	< 0.19	< 0.14	< 0.12
Balance quality level per DIN ISO 1940		G 2.5								
Max. limits for relative shaft vibration (peak-to-peak)¹⁸⁾ Undulations in the connection flange area, based on ISO 7919-3										
Normal operation (continuous operation)	μm	$s_{(p-p)} = \frac{9000}{\sqrt{n}}$ (n in rpm)								
Start and stop operation/resonance ranges (temporary)	μm	$s_{(p-p)} = \frac{13200}{\sqrt{n}}$ (n in rpm)								
Mass moment of inertia of rotor J_v										
without rotational speed measuring system	kg·m ²	0.0010	0.0010	0.0017	0.0039	0.0128		0.0292	0.0771	
with magn. rotational speed meas. system	kg·m ²	0.0015	0.0015	0.0022	0.0048	0.0145	0.0146	0.0333	0.0872	
Proportional mass moment of inertia for the transmitter side (side of the flange with external centering)										
without rotational speed measuring system	% of J_v	68	68	62	59	54		53	54	
with magn. rotational speed meas. system	% of J_v	44	44	48	48	48		47	48	
Max. permissible static eccentricity of the rotor (radially) to the center point of the stator										
without rotational speed measuring system	mm	± 2								
Permissible axial displacement between rotor and stator ¹⁹⁾										
without rotational speed measuring system	mm	± 2								
Weight										
Rotor without rotational speed measuring system										
Rotor with magn. rotational speed meas. system	kg	0.7	0.7	1.1	1.9	3.8	3.9	6.5	10.9	
Stator	kg	0.8	0.8	1.3	2.1	4.1	4.1	6.9	11.7	
	kg	1.1	1.1	1.1	1.1	1.1	1.1	1.2	1.3	

¹⁸⁾ The influence of radial deviations, impact, defects of form, notches, marks, local residual magnetism, structural variations or material anomalies on the vibrational measurements needs to be taken into account and isolated from the actual undulation.

¹⁹⁾ Above the nominal (rated) temperature range: ± 1.5 mm.

Radial and axial run-out tolerances

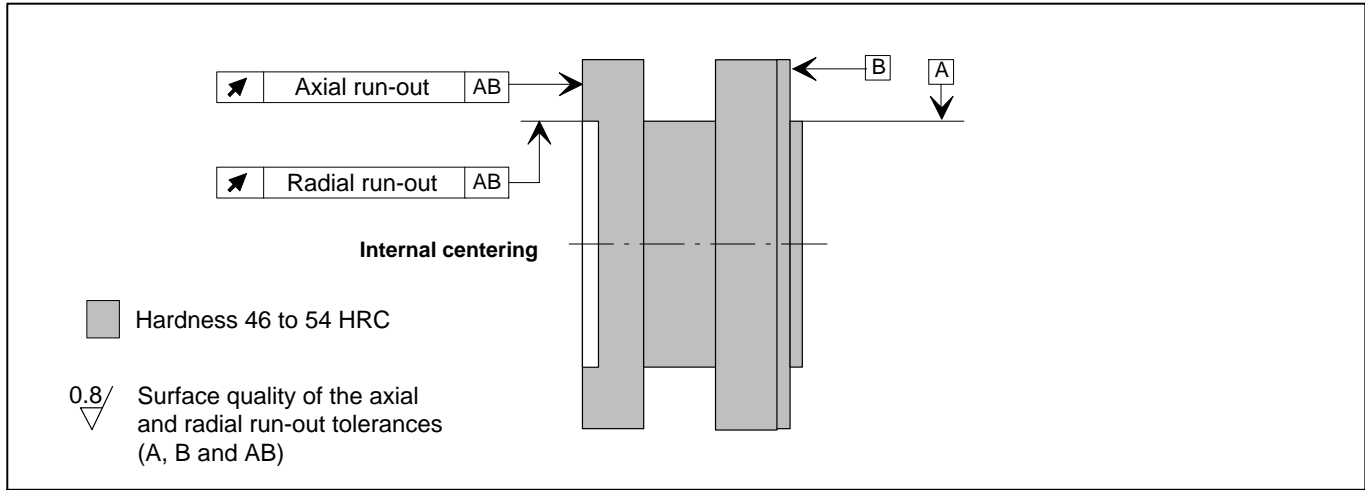

Measuring range (N·m)	Axial runout tolerance (mm)	Radial run-out tolerance (mm)
50	0.01	0.01
100	0.01	0.01
200	0.01	0.01
500	0.01	0.01
1 k	0.01	0.01
2 k	0.02	0.02
3 k	0.02	0.02
5 k	0.02	0.02
10 k	0.02	0.02

Dimensions of T40B 50 Nm - 100 Nm without rotational speed measurement

Dimensions in mm (1 mm = 0.03937 inches)
 Dimensions without tolerances, per DIN ISO 2768-mk

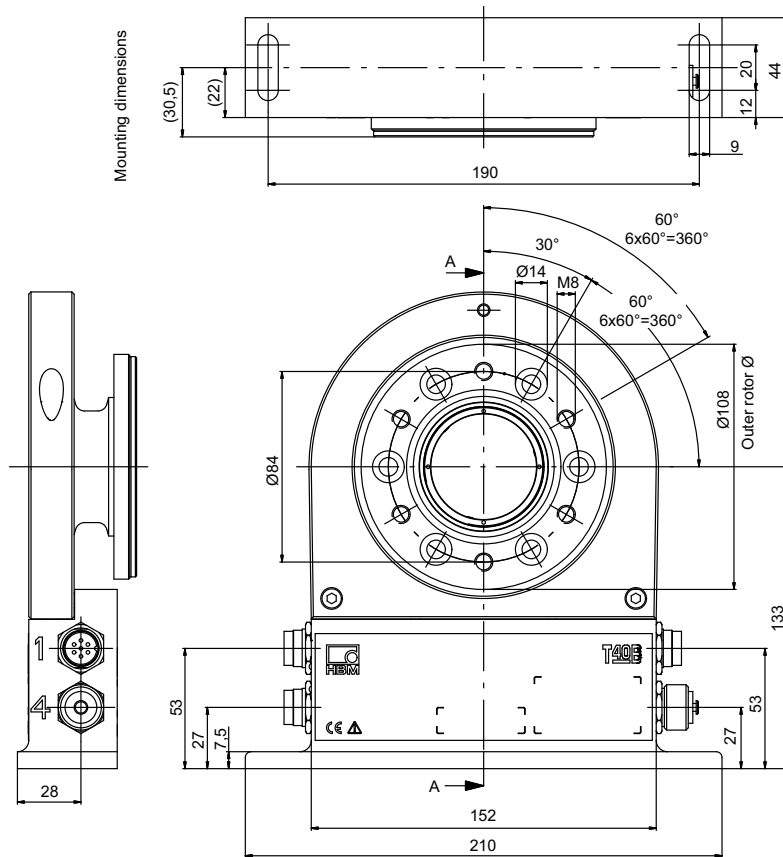

Dimensions of T40B 50 Nm - 100 Nm without rotational speed measurement, continued

Dimensions in mm (1 mm = 0.03937 inches)
 Dimensions without tolerances, per DIN ISO 2768-mk

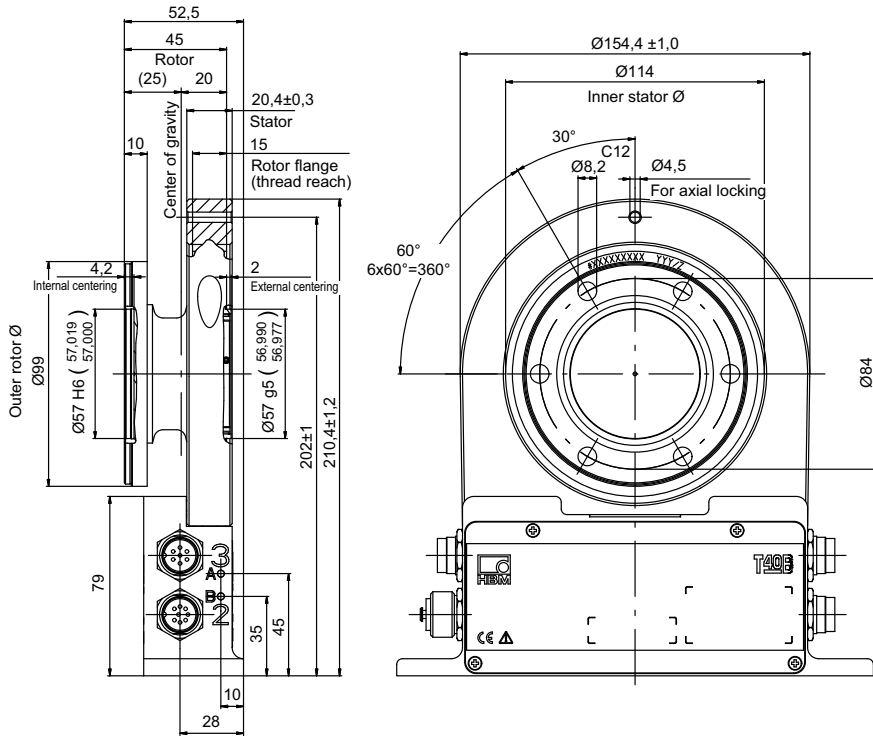

Partial sections cut A-A

Dimensions of T40B 200 Nm without rotational speed measurement

Dimensions in mm (1 mm = 0.03937 inches)
 Dimensions without tolerances, per DIN ISO 2768-mk

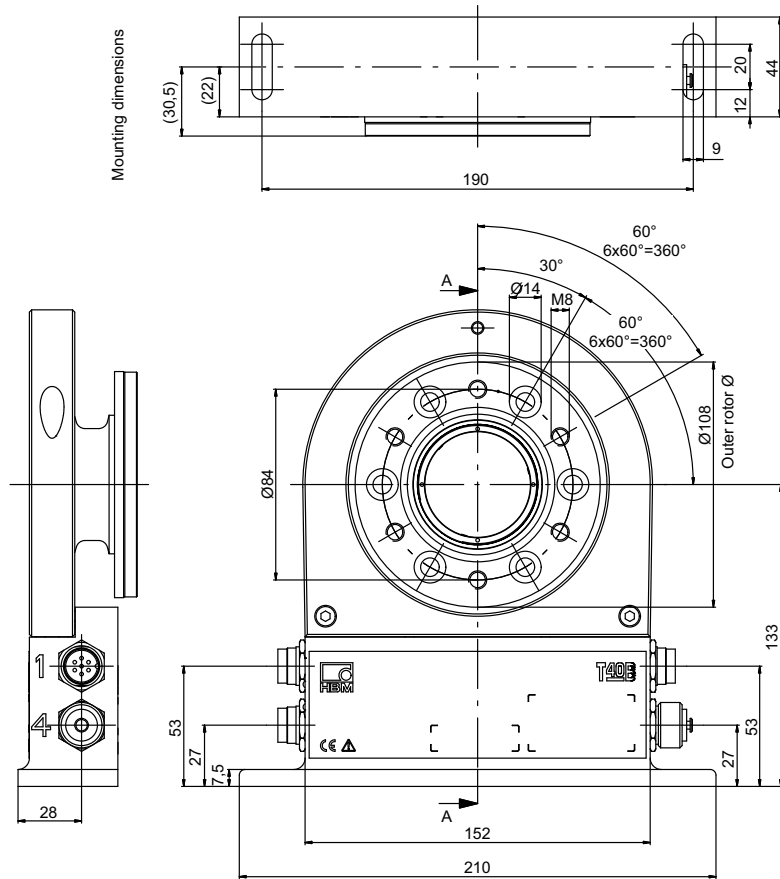

Dimensions of T40B 200 Nm without rotational speed measurement, continued

Dimensions in mm (1 mm = 0.03937 inches)
 Dimensions without tolerances, per DIN ISO 2768-mk

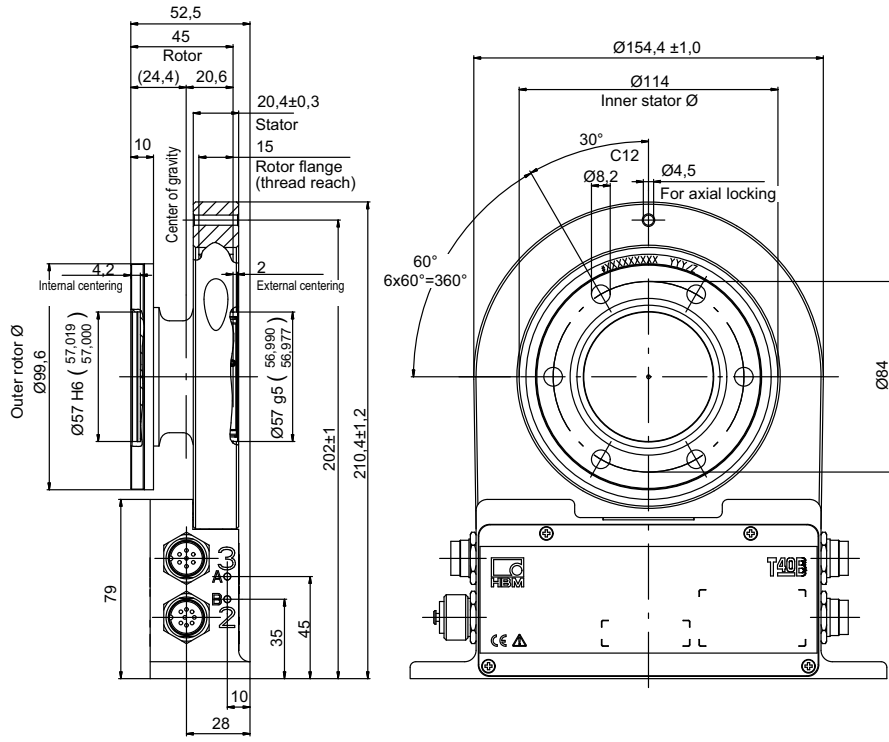

Partial sections cut A-A

Dimensions of T40B 500 Nm - 1 kNm without rotational speed measurement

Dimensions in mm (1 mm = 0.03937 inches)
 Dimensions without tolerances, per DIN ISO 2768-mk

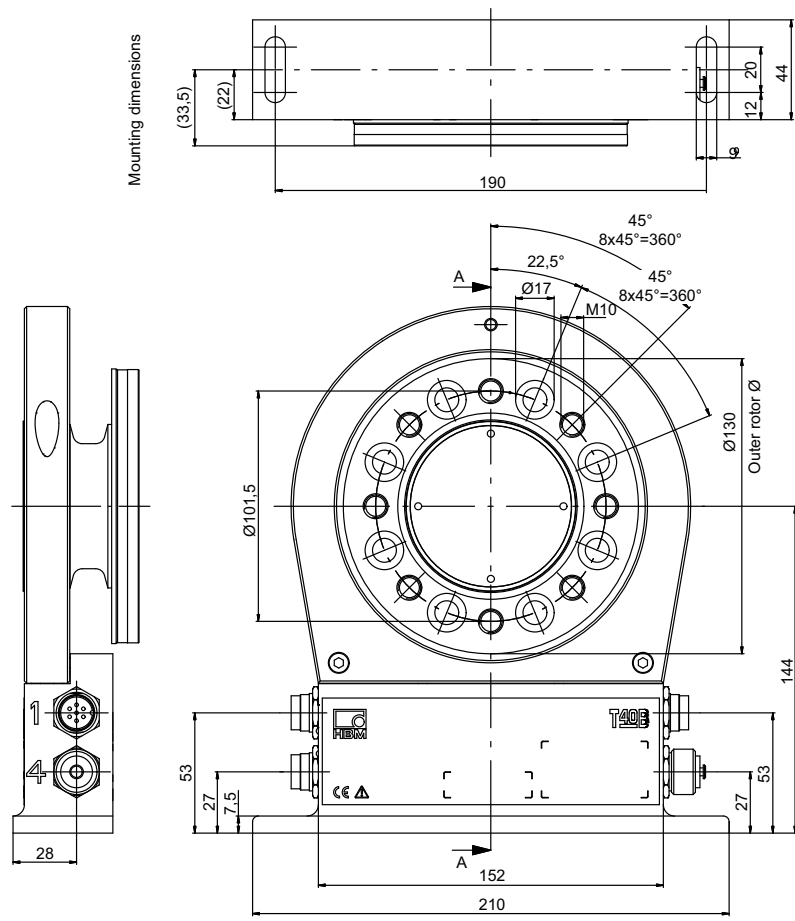

Dimensions of T40B 500 Nm - 1 kNm without rotational speed measurement, continued

Dimensions in mm (1 mm = 0.03937 inches)

Dimensions without tolerances, per DIN ISO 2768-mk

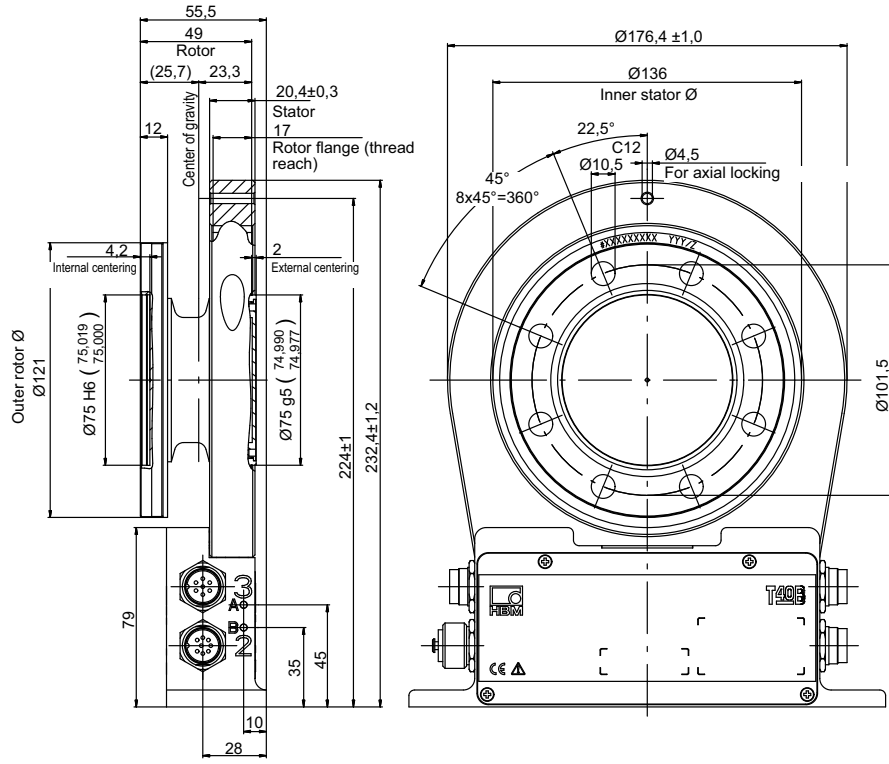

Partial sections cut A-A

Dimensions of T40B 2 kNm - 3 kNm without rotational speed measurement

Dimensions in mm (1 mm = 0.03937 inches)
 Dimensions without tolerances, per DIN ISO 2768-mk

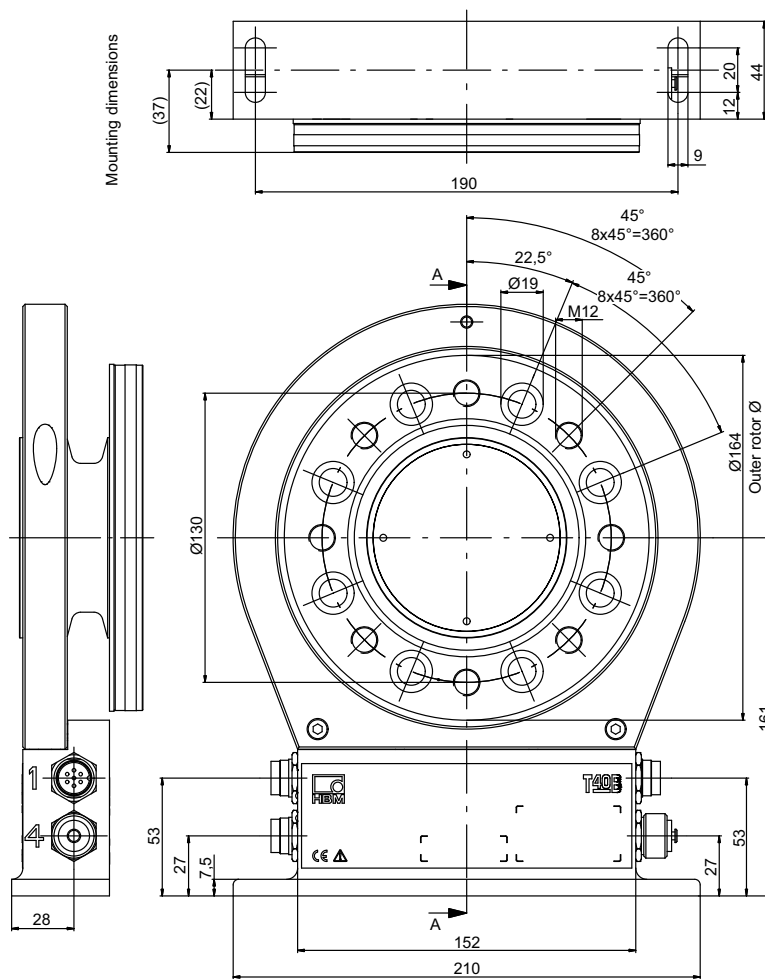

Dimensions of T40B 2 kNm - 3 kNm without rotational speed measurement, continued

Dimensions in mm (1 mm = 0.03937 inches)

Dimensions without tolerances, per DIN ISO 2768-mk

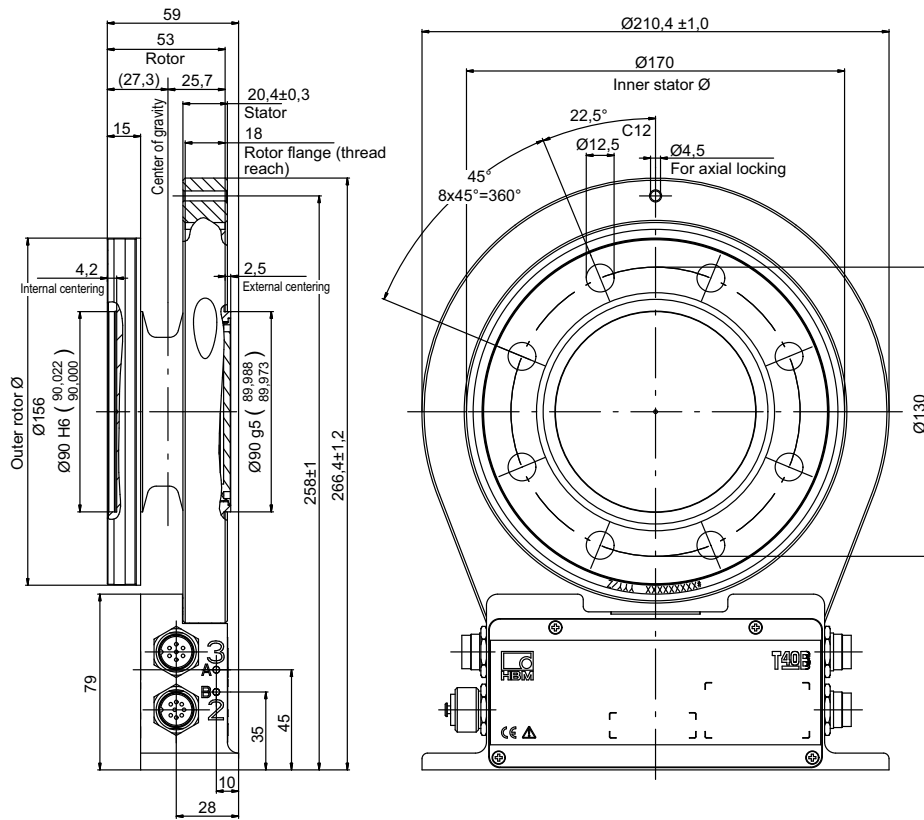

Partial sections cut A-A

Dimensions of T40B 5 kNm without rotational speed measurement

Dimensions in mm (1 mm = 0.03937 inches)
Dimensions without tolerances, per DIN ISO 2768-mk

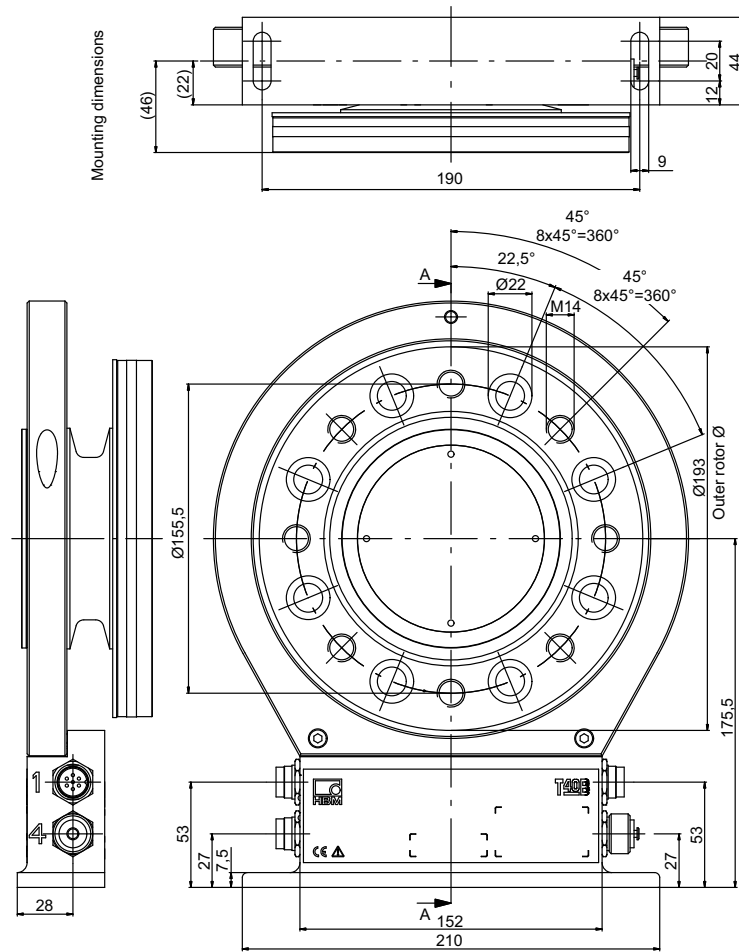

Dimensions of T40B 5 kNm without rotational speed measurement, continued

Dimensions in mm (1 mm = 0.03937 inches)

Dimensions without tolerances, per DIN ISO 2768-mk

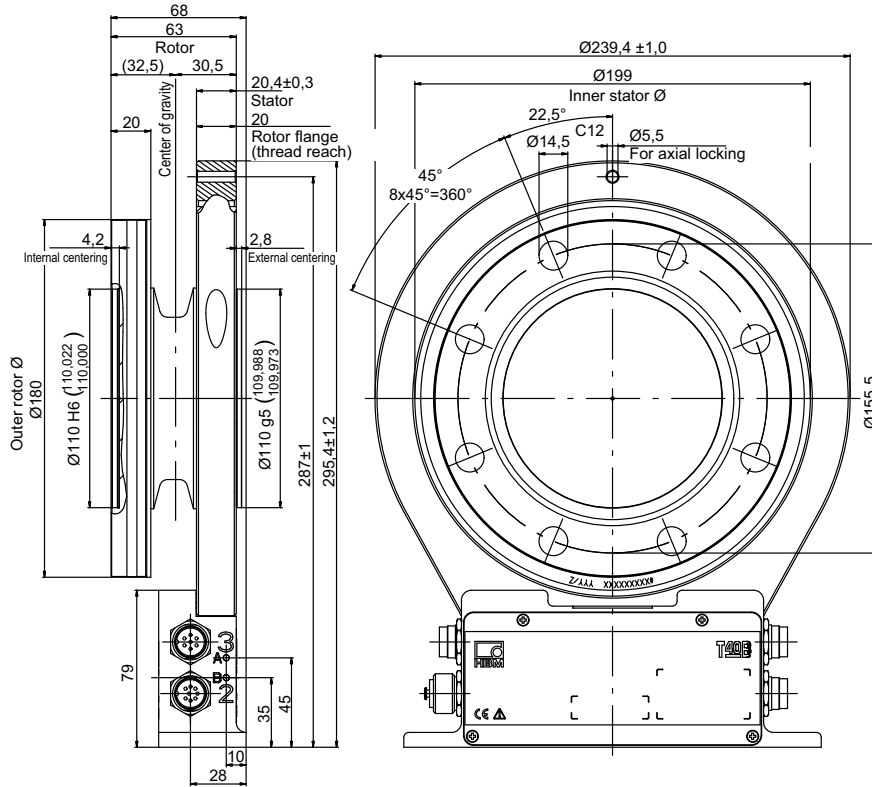

Partial sections cut A-A

Dimensions of T40B 10 kNm without rotational speed measurement

Dimensions in mm (1 mm = 0.03937 inches)
 Dimensions without tolerances, per DIN ISO 2768-mk

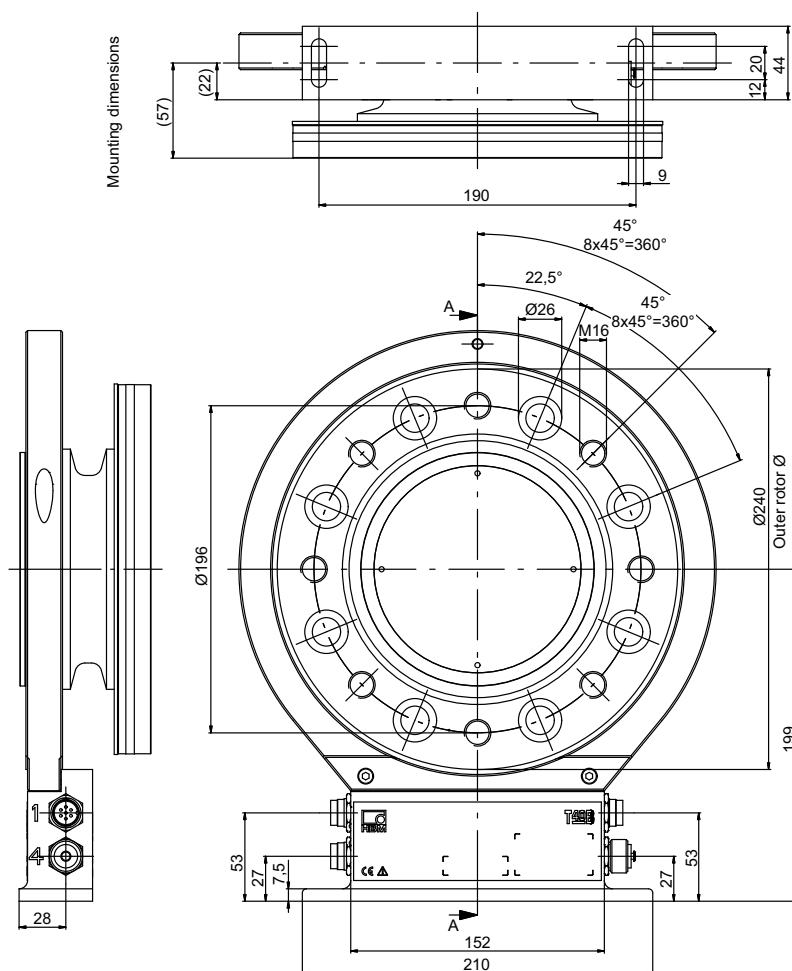

Dimensions of T40B 10 kNm without rotational speed measurement, continued

Dimensions in mm (1 mm = 0.03937 inches)
 Dimensions without tolerances, per DIN ISO 2768-mk

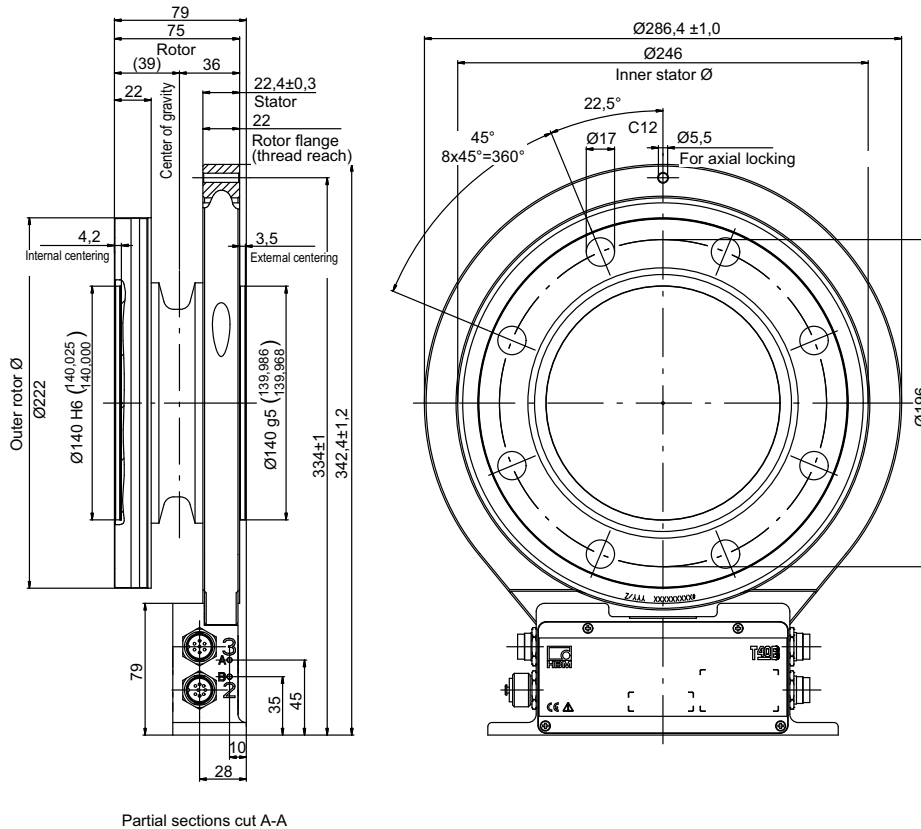

Dimensions of T40B 50 Nm - 100 Nm with rotational speed measurement and reference signal

Dimensions in mm (1 mm = 0.03937 inches)
 Dimensions without tolerances, per DIN ISO 2768-mk

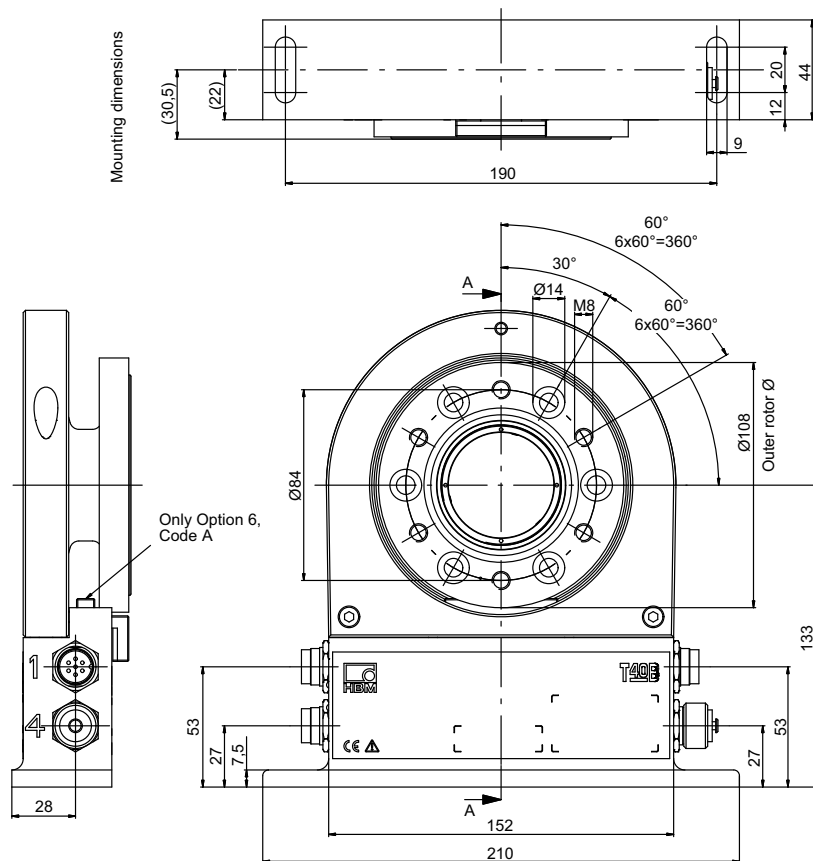

Dimensions of T40B 50 Nm - 100 Nm with rotational speed measurement and reference signal, continued

Dimensions in mm (1 mm = 0.03937 inches)

Dimensions without tolerances, per DIN ISO 2768-mk

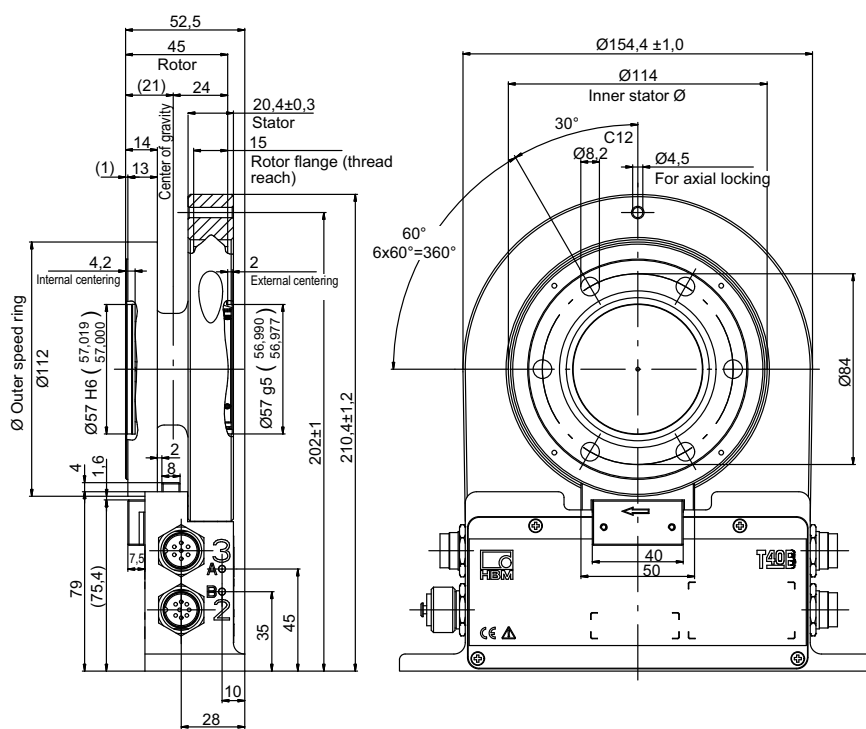

Partial sections cut A-A

Dimensions of T40B 200 Nm with rotational speed measurement and reference signal

Dimensions in mm (1 mm = 0.03937 inches)
 Dimensions without tolerances, per DIN ISO 2768-mk

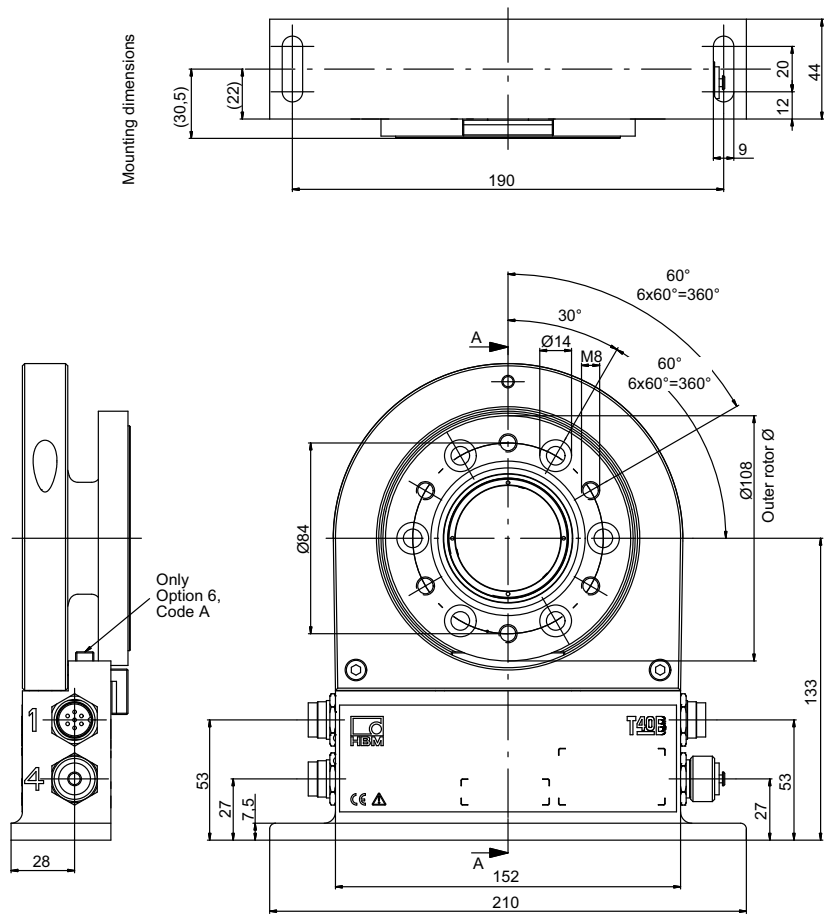

Dimensions of T40B 200 Nm with rotational speed measurement and reference signal, continued

Dimensions in mm (1 mm = 0.03937 inches)

Dimensions without tolerances, per DIN ISO 2768-mk

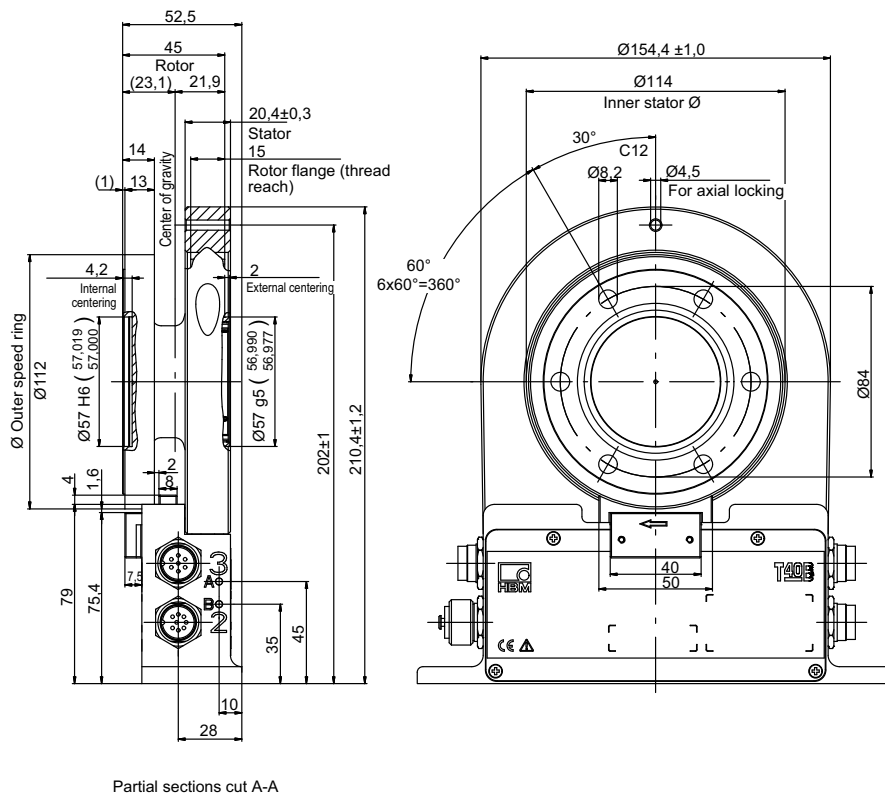

Partial sections cut A-A

Dimensions of T40B 500 Nm - 1 kNm with rotational speed measurement and reference signal

Dimensions in mm (1 mm = 0.03937 inches)
 Dimensions without tolerances, per DIN ISO 2768-mk

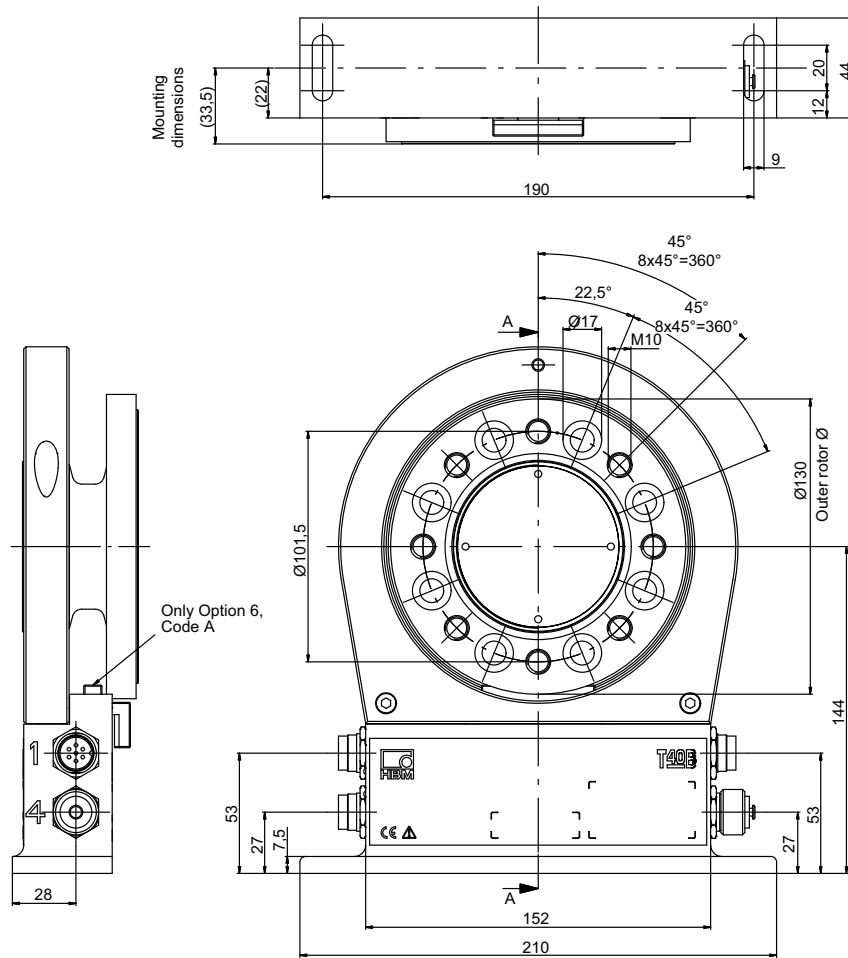

Dimensions of T40B 500 Nm - 1 kNm with rotational speed measurement and reference signal, continued

Dimensions in mm (1 mm = 0.03937 inches)

Dimensions without tolerances, per DIN ISO 2768-mk

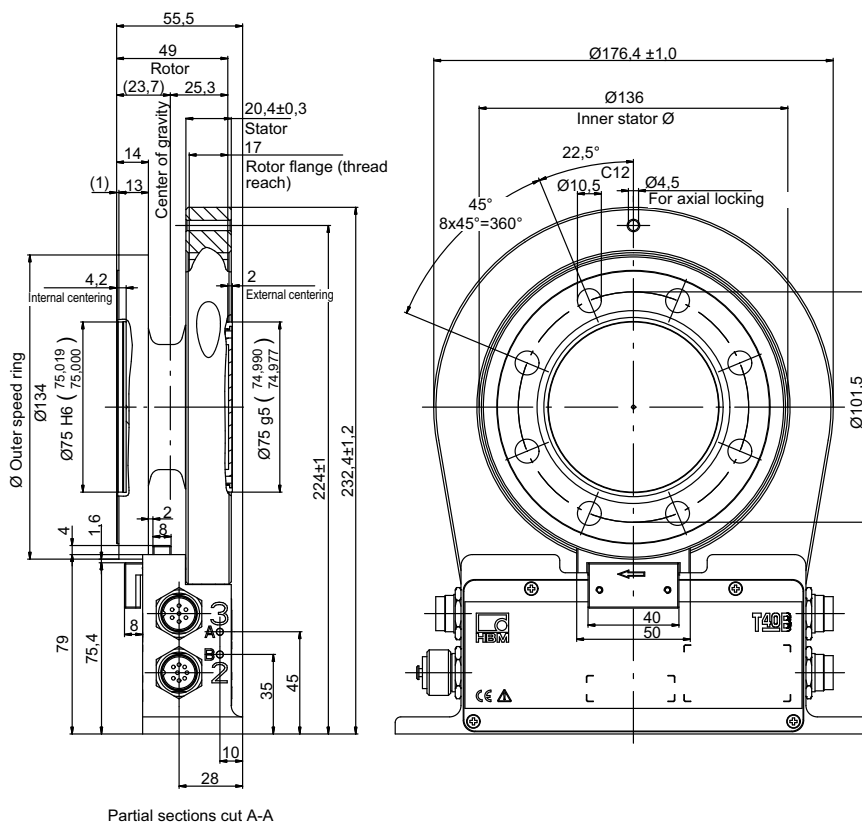

Dimensions of T40B 2 kNm - 3 kNm with rotational speed measurement and reference signal

Dimensions in mm (1 mm = 0.03937 inches)
 Dimensions without tolerances, per DIN ISO 2768-mk

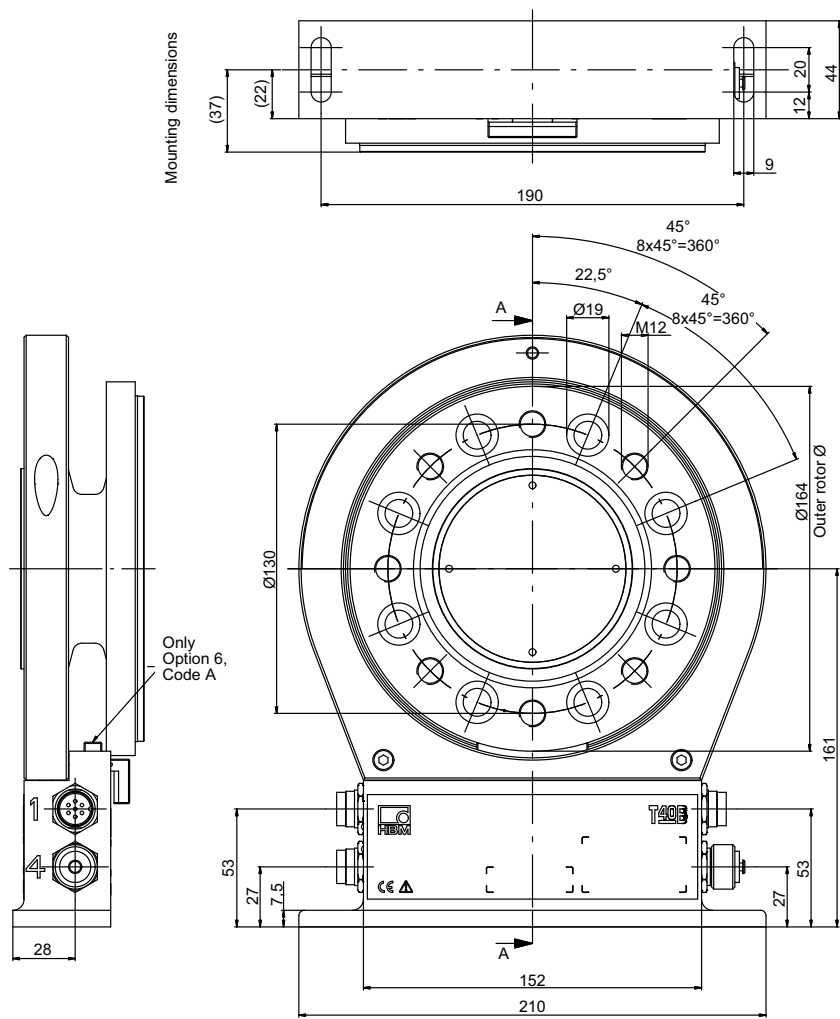

Dimensions of T40B 2 kNm - 3 kNm with rotational speed measurement and reference signal, continued

Dimensions in mm (1 mm = 0.03937 inches)

Dimensions without tolerances, per DIN ISO 2768-mk

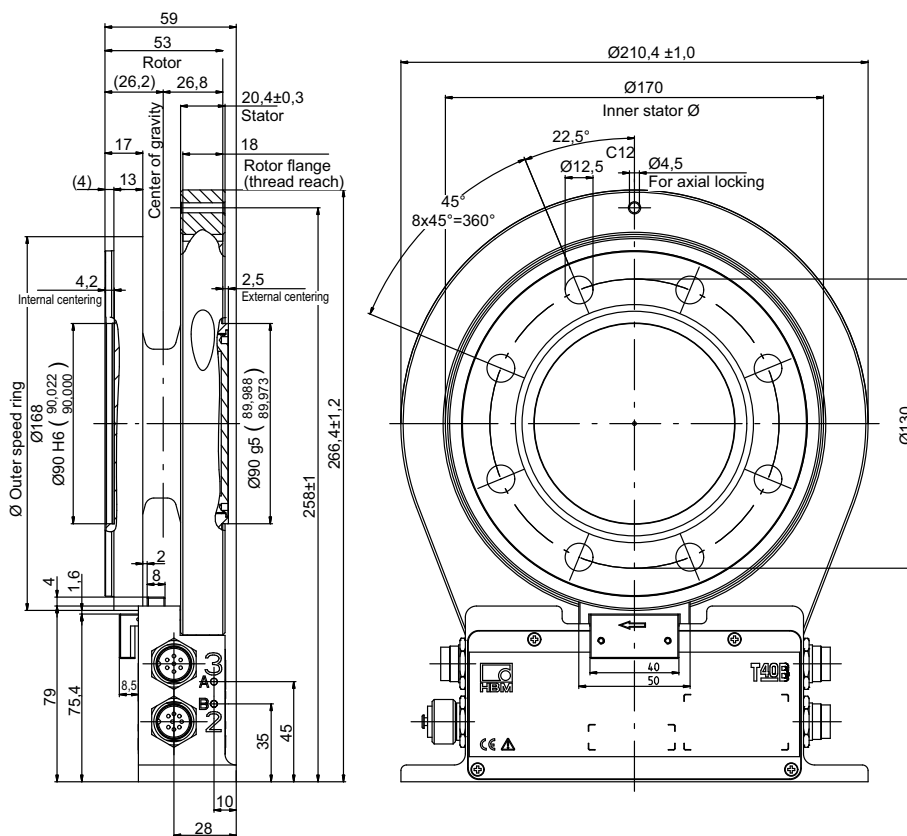

Partial sections cut A-A

Dimensions of T40B 5 kNm with rotational speed measurement and reference signal

Dimensions in mm (1 mm = 0.03937 inches)
 Dimensions without tolerances, per DIN ISO 2768-mk

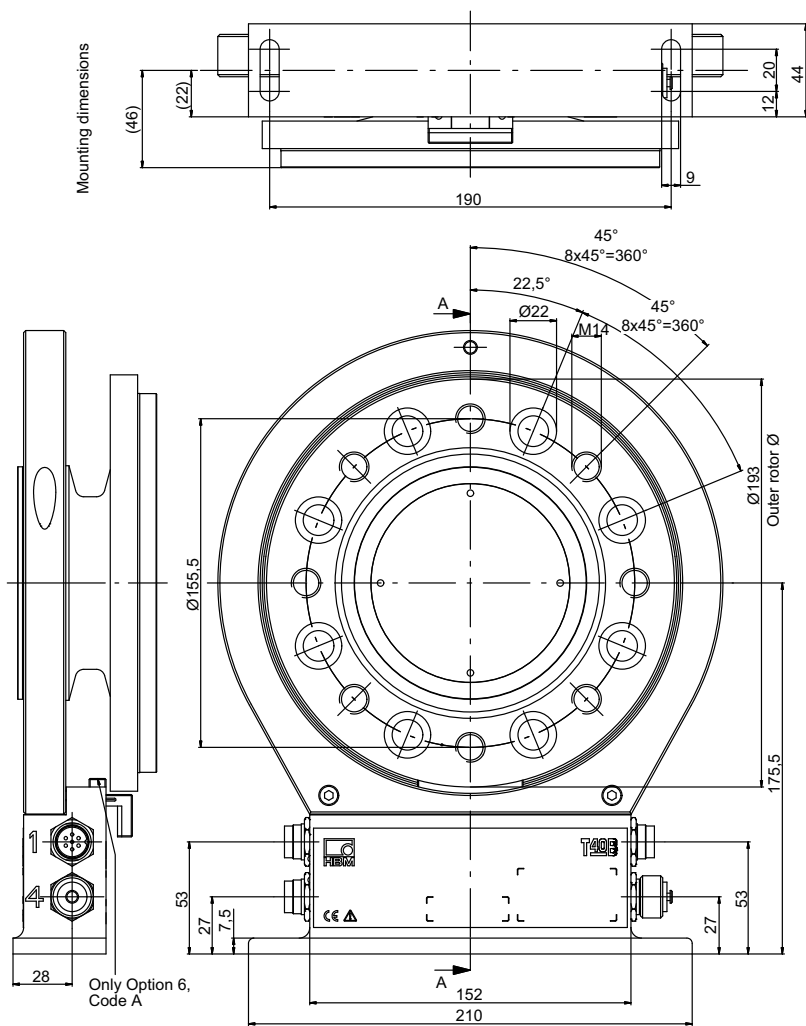

Dimensions of T40B 5 kNm with rotational speed measurement and reference signal, continued

Dimensions in mm (1 mm = 0.03937 inches)
 Dimensions without tolerances, per DIN ISO 2768-mk

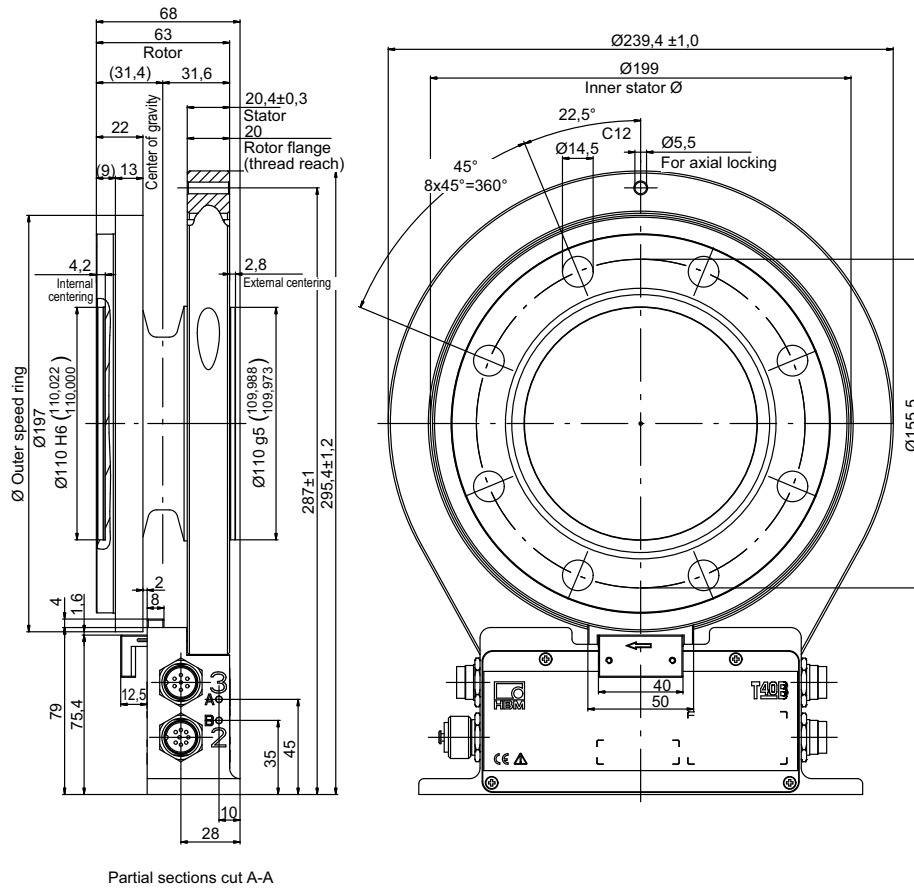

Dimensions of T40B 10 kNm with rotational speed measurement and reference signal

Dimensions in mm (1 mm = 0.03937 inches)
 Dimensions without tolerances, per DIN ISO 2768-mk

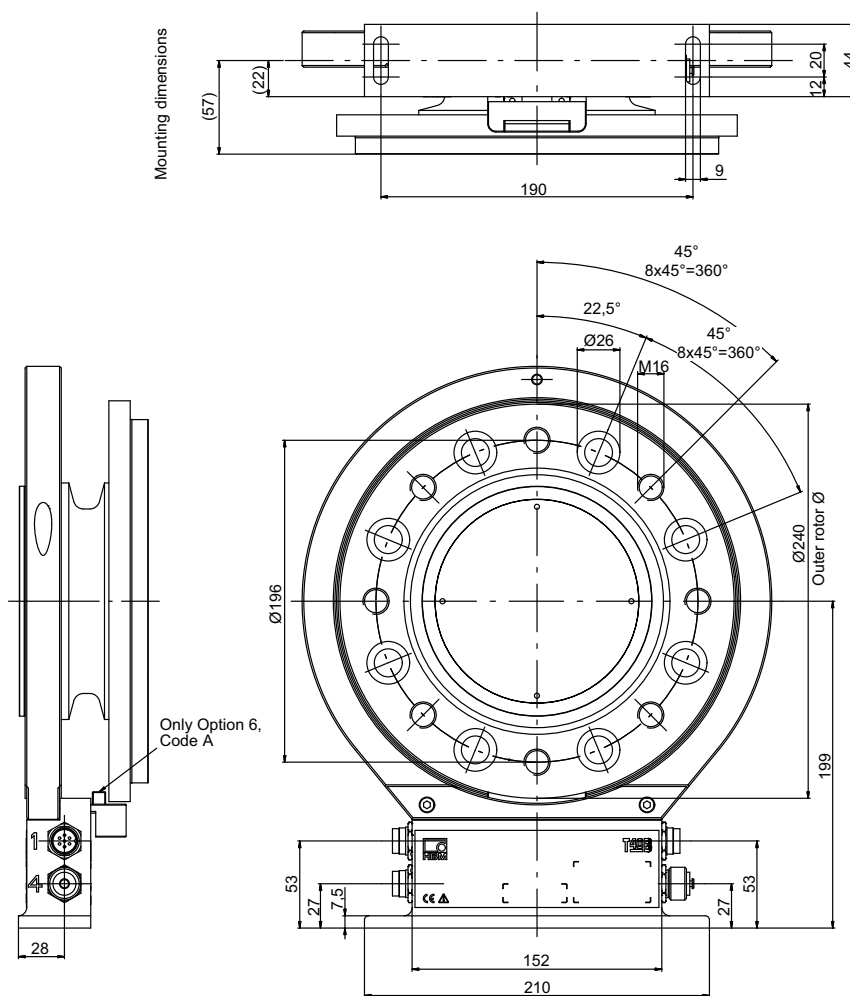

Dimensions of T40B 10 kNm with rotational speed measurement and reference signal, continued

Dimensions in mm (1 mm = 0.03937 inches)

Dimensions without tolerances, per DIN ISO 2768-mk

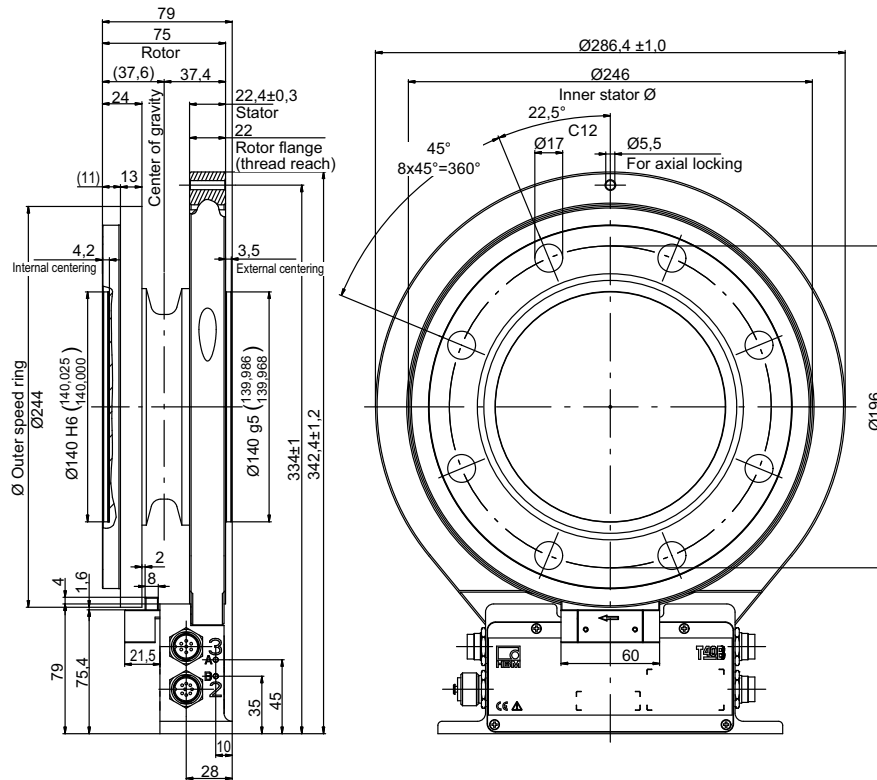

Partial sections cut A-A

Ordering numbers

K-T40B [only with Option 2 = MF / ST]

Code	Option 1: Measuring range up to
050Q	50 N·m [only with Option 2 = MF / RO]
100Q	100 N·m [only with Option 2 = MF / RO]
200Q	200 N·m [only with Option 2 = MF / RO]
500Q	500 N·m [only with Option 2 = MF / RO]
001R	1 kN·m [only with Option 2 = MF / RO]
002R	2 kN·m [only with Option 2 = MF / RO]
003R	3 kN·m [only with Option 2 = MF / RO]
005R	5 kN·m [only with Option 2 = MF / RO]
010R	10 kN·m [only with Option 2 = MF / RO]

Code	Option 2: Component
MF	Measurement flange, complete
RO	Rotor
ST	Stator

Code	Option 3: Accuracy
S	Standard

Code	Option 4: Nominal speed range
M	Standard speed
H	High speed

Code	Option 5: Electrical configuration	[only with Option 2 = MF / ST]
SU2	10 kHz ±5 kHz and ±10 V output signal, 18...30 V DC supply voltage	
DU2	60 kHz ±30 kHz and ±10 V output signal, 18...30 V DC supply voltage	
HU2	240 kHz ±120 kHz and ±10 V output signal, 18...30 V DC supply voltage	

Code	Option 6: Rotational speed measuring system
0	Without rot. speed measuring system
1	Magnetic rot. speed measuring system; 1024 pulses/revolution
2	Magnetic rot. speed measuring system; 128 pulses/revolution
A	Magnetic rot. speed measuring system; 1024 pulses/revolution with reference pulse
B	Magnetic rot. speed measuring system; 128 pulses/revolution with reference pulse

Code	Option 7: Customised modification
U	No customer-specific modification

K-T40B- - - - **S** - **M** - - - **U** = PREFERENCE Types

Accessories, to be ordered separately

Article	Order no.
Connection cable, set	
Torque connection cable, Binder 423 - D-Sub 15P, 6 m	1-KAB149-6
Torque connection cable, Binder 423 - free ends, 6 m	1-KAB153-6
Rotational speed connection cable, Binder 423 - 8-pin, free ends, 6 m	1-KAB154-6
Rotational speed connection cable, Binder 423 - 8-pin D-Sub, free ends, 6 m	1-KAB150-6
Rotational speed connection cable, reference signal, Binder 423 - 15-pin D-Sub, 6 m	1-KAB163-6
Rotational speed connection cable, reference signal, Binder 423 - 8-pin, free ends, 6 m	1-KAB164-6
TMC connection cable, Binder 423 - 16-pin, free ends, 6 m	1-KAB174-6
Cable sockets	
423G-7S, 7-pin (straight)	3-3101.0247
423W-7S, 7-pin (angular)	3-3312.0281
423G-8S, 8-pin (straight)	3-3312.0120
423W-8S, 8-pin (angular)	3-3312.0282
Connection cable, by the meter (min. order quantity: 10 m, price per meter)	
Kab8/00-2/2/2	4-3301.0071

Subject to modifications.
All product descriptions are for general information only. They are not to be understood as a guarantee of quality or durability.

托驰（上海）工业传感器有限公司
上海市嘉定区华江路348号1号楼707室
电话：+86 021 51069888
传真：+86 021 51069009
邮箱：zhang@yanatoo.com
网址：www.sensor-hbm.com

measure and predict with confidence

